

POLYMIX®

DISPERSING AND MIXING TECHNOLOGY BY KINEMATICA

Micro Milling Technology in the Laboratory



System POLYMIX® PX-MFC 90 D
Hammer mill &
Blade mill



KINEMATICA.CH
Dispensing and Mixing Technology

POLYMIX® System PX-MFC 90 D - lab grinding mill

KINEMATICA is the leading manufacturer of homogenizing, mixing and milling equipment based on our technology of rotor/stator dispersing principles.

With the **new designed POLYMIX® System PX-MFC 90 D** KINEMATICA presents now the successor of the famous POLYTRON® System PX-MFC - Culatti Micro Hammer Mill.

The new PX-MFC 90 D is suitable for all dry milling applications in the lab and is designed with many new features: a more powerful motor, an integrated frequency inverter with LED-display, a new designed milling chamber with exchangeable grinding attachments, a new base frame with integrated handle and much more.

Special features of the PX-MFC 90 D:

- **500% more power (1000 W, 3-phase motor) than former model PX-MFC**
- **Speeds up to 6'000 rpm**
- **Low noise level due to brushless 3-phase AC motor**
- **Integrated speed control with LED-display for speed indication and status messages**
- **Integrated overheating, overload and blocking protection**
- **Safety switch for automatic-Off**
- **Energy saving through automatic Standby-mode**
- **Milling chamber with attached funnel and rotary slide for product inlet dosage; intercepting tubes and NS29 vessels can be attached to milling chamber outlet**
- **Milling chamber can be equipped with hammer grinding or blade grinding attachment**
- **Milling chamber can be equipped with sieves in different mesh sizes from 0.2 up to 6 mm**
- **Milling chamber parts in contact with the product made from stainless steel hardened**
- **Base frame made from anodised aluminium with integrated handle**



PX-MFC 90 D basic unit with milling chamber and connected intercepting tube



Front panel with Safety On/Off switch, control knob and LED display for speed indication and status messages

POLYMIX® PX-MFC 90 D	
Technical Data	
Working volume (funnel)	approx. 300 ml (volume of the funnel)
Motor type / power	3-phase AC motor; up to 1000 W input / up to 600 W output
Supply voltage / frequency	230V / 50 Hz or 100-120V / 60 Hz
Speed range	50 - 6'000 rpm
Display	LED
Noise emission (drive only)	lower 70 dB(A) at 6'000 rpm (no load)
Dimensions / Weight	251 x 325 x 480 / approx. 12 kg
Environment	0-40°C, 95% rel. humidity
Protection class	IP 20
Certified standards	EMC according to IEC/EN 61000-6-2 / EN 61000-6-3 Safety according to IEC/EN 61010-2-51



Milling chamber with Safety switch, funnel, lid, rotary slide for product dosage and NS29 adapter for intercepting tubes



General laboratory equipment from KINEMATICA - a complete SWISS quality program. Ask for further information to your application. Our sales team will be glad to assist you.

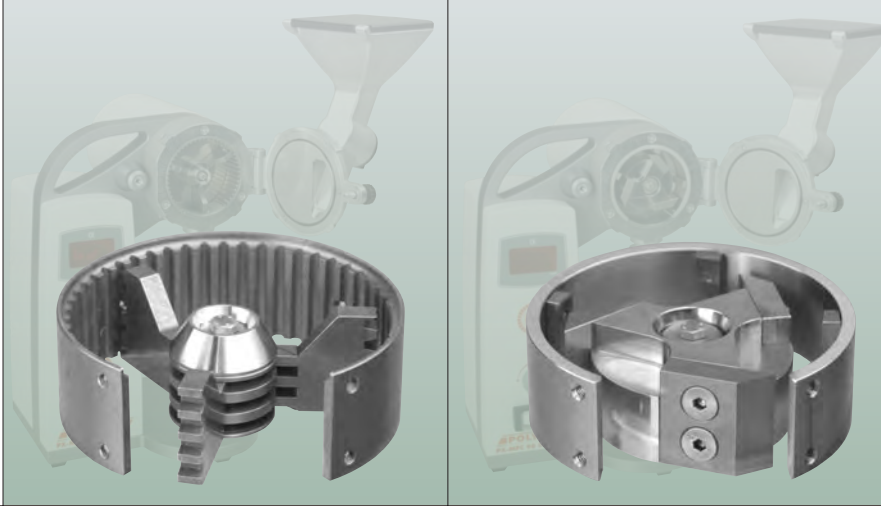

Type	Hammer grinding attachment	Blade grinding attachment
Description	Consisting of rotor with 3 impact hammers and stator with place for one exchangeable sieve	Consisting of rotor with 3 attached blades and stator with place for one exchangeable sieve
Applications	<p>The impact grinding mill attachment is designed for processing dried, non-fatty, hard and brittle products such as:</p> <p>Cereals, corn, malt, pectin, raw & roasted coffee, beans, oats, nutshells, bones, fins (fish), gravel, stone, amber, mortar, etc.</p>	<p>The blade grinding mill attachment is designed for processing dried, non-fatty, stringy and ductile products such as:</p> <p>Wood, bark, roots, leaves, straw, cork, dried fruits, dried degreased meat, adenoids, fish, feathers, leather, dermis, wool, cotton, leashes, paper, coal, turf, dried resins, synthetic materials, fibre glass, plastic pellets, different textiles, felt, etc.</p>



Different available sieves with mesh sizes from 0.2 mm up to 6 mm

Order Information for POLYMIX® PX-MFC 90 D

Please find below the order information for the basic units, grinding attachments, sieves and accessories:

Order Code	Description
Basic units (incl. milling chamber, grinding attachment, sieve 2.0 mm and tool set)	
35010020	PX-MFC 90 D, drive unit, 230V/CH (with CH-cable), milling chamber, Hammer grinding attachment, sieve 2.0 mm and tool set
35010021	PX-MFC 90 D, drive unit, 230V/EU (with EU-cable), milling chamber, Hammer grinding attachment, sieve 2.0 mm and tool set
35010022	PX-MFC 90 D, drive unit, 230V/UK (with UK-cable), milling chamber, Hammer grinding attachment, sieve 2.0 mm and tool set
35010023	PX-MFC 90 D, drive unit, 100-120V (with cable), milling chamber, Hammer grinding attachment, sieve 2.0 mm and tool set
35010030	PX-MFC 90 D, drive unit, 230V/CH (with CH-cable), milling chamber, Blade grinding attachment, sieve 2.0 mm and tool set
35010031	PX-MFC 90 D, drive unit, 230V/EU (with EU-cable), milling chamber, Blade grinding attachment, sieve 2.0 mm and tool set
35010032	PX-MFC 90 D, drive unit, 230V/UK (with UK-cable), milling chamber, Blade grinding attachment, sieve 2.0 mm and tool set
35010033	PX-MFC 90 D, drive unit, 100-120V (with cable), milling chamber, Blade grinding attachment, sieve 2.0 mm and tool set

Grinding attachments

35031001	Hammer grinding attachment
35031002	Blade grinding attachment

Sieves

9609088	Sieve with mesh size 0.2 mm
9609089	Sieve with mesh size 0.5 mm
9609090	Sieve with mesh size 0.8 mm
9609092	Sieve with mesh size 1.0 mm
9609093	Sieve with mesh size 1.5 mm
9609094	Sieve with mesh size 2.0 mm
9609091	Sieve with mesh size 3.0 mm
9609105	Sieve with mesh size 4.0 mm
9609106	Sieve with mesh size 5.0 mm
9609107	Sieve with mesh size 6.0 mm

Accessories

35080001	Stodger
9609114	Wooden Stand for/with 12 intercepting tubes



Well suited stodger for safe and easy stodging till the entrance of the milling chamber (shown with blade grinding attachment)



Practical wooden stand with 12 intercepting tubes and box for toolset

Finest Solutions ... worldwide!

A wide range of products with the finest solution for every application, matched by the superior quality of all components make KINEMATICA a world leader for Dispersing and Mixing technology.

With Keen Eyes ...

Development knows no rest at KINEMATICA. Our systems are constantly upgraded to reflect the state-of-the-art technology and the needs of the market. KINEMATICA has always had a keen eye for major advances, as proved by various patents.

The rotor/stator principle for dispersing technology was conceived and developed at KINEMATICA and has become the world standard.

... For Your Needs

Applications for Dispersing/Homogenizing Technology are always on the increase. KINEMATICA continually creates new areas of processing applications based on innovations. We do not neglect the human factor as it is exemplified by the noise reduction of our high-speed systems.

Please, get in touch with us, our local appointed agent or your preferred dealer. We will be pleased to supply more details or arrange for a personal demonstration of our POLYTRON® and MEGATRON® systems.

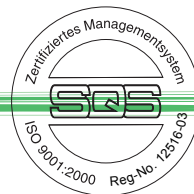

POLYTRON **BIOTRONA** **MEGATRON** **REACTRON** **POLYMIX**

Dispersing Technology for Laboratory and Pilot Plant
Batch- and In-Line-Dispersing equipment



 **KINEMATICA.CH**
Dispersing and Mixing Technology

POLYTRON **BIOTRONA** **MEGATRON** **REACTRON** **POLYMIX**

Homogenizing and Dispersing Technology
In-line- und Batch-Prozessoren for Pilot Plant- and Production



 **KINEMATICA.CH**
Dispersing and Mixing Technology

Headquarters



KINEMATICA AG

Dispersing- and Mixing Technology

Luzernerstrasse 147a
CH-6014 Littau / Lucerne
Switzerland

Tel. +41-41-259 65 65
Fax +41-41-259 65 75
e-Mail laboratory@kinematica.ch
web www.kinematica.ch

Subsidiary



KINEMATICA, INC.

Dispersing- and Mixing Technology

211 Warren Street, Suite 406
Newark, NJ 07103
USA

Tel. (973) 242 - 4003
Fax (973) 242 - 4008
e-Mail kinematica@msn.com
web www.kinematica.ch